

## Data Acquisition Front-End



- ✓ Industrial, universal, modular front-end for acoustical and vibration measurements
- ✓ up to 8 universal channels for analog voltage or IEPE with high resolution A/D converters
- ✓ 4 high resolution RPM channels
- ✓ Optional optical SPDIF channel for torsional vibration (see TAC sensor)
- ✓ Modularity enables optimal configuration for your testing application

## TAS28A

TAS28A is a modular multi-channel data acquisition front-end with the following features:

- ADC: Up to 8 analog voltage / IEPE channels with 24bit / 200kHz A/D converters
- RPM: 4 high resolution isolated RPM inputs on-board, easily expandable with further modules
- Sampling: 2 main system clocks are available, providing either 24/48/96/192kHz or 25/50/100/200kHz sampling rates
- USB 2.0 high speed interface to the host PC
- Dimensions: 102.7mm × 230mm × 20.6mm, 715g, in a robust aluminum housing

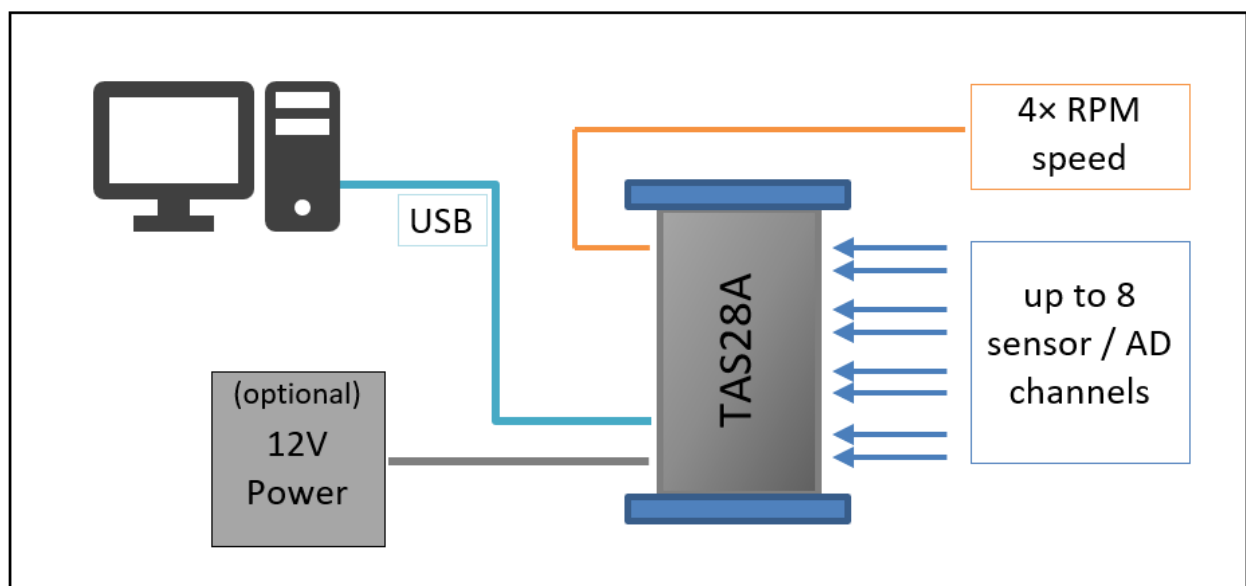

## Specifications

The following pages contain the specifications of the base system and available modules.

- 1 [TAS28A Environmental & Dimensions](#)
- 2 [TAS28A BASE – USB Interface](#)
- 3 [TAD48 – Analog Input, Low Power](#)
- 4 [TAD48+ – Analog Input, High End](#)
- 5 [TIS48 – RPM / Encoder Input](#)
  - 5.1 [TIS Connector](#)
- 6 [TAS48 SPOVL – Optical Digital Input](#)
- 7 [Power Considerations for Mobile Systems](#)

TAS28A can contain up to 4 input modules and always has a built-in TIS module:

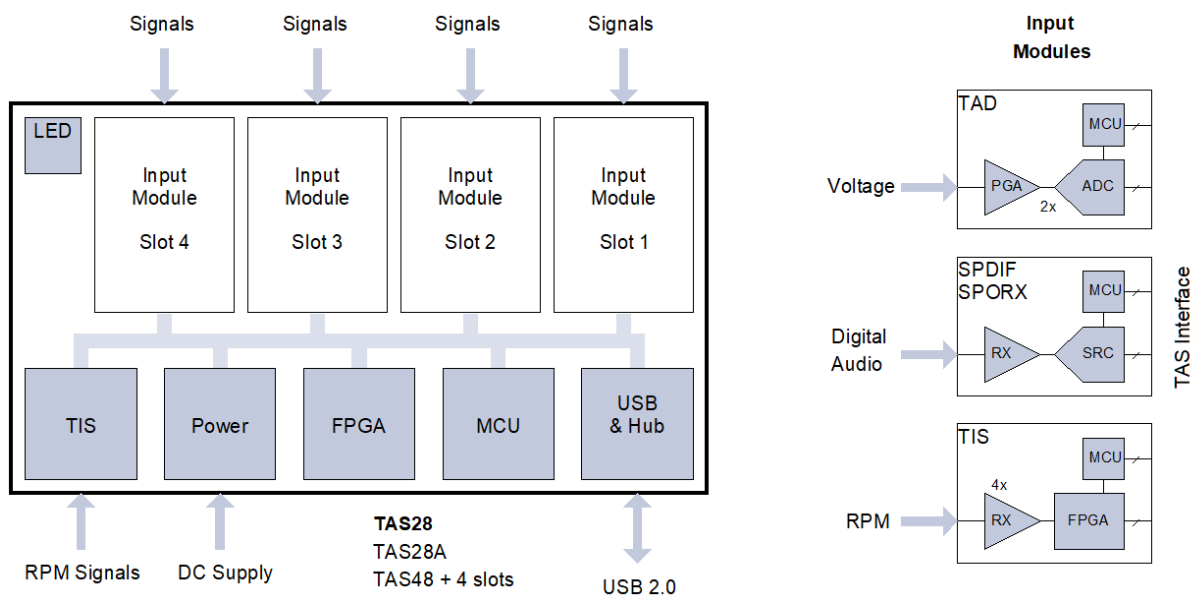

Picture above: block diagram of TAS base card and modules

## 1 TAS28A Environmental & Dimensions

TAS28A System Specifications		
<b>Environment</b>		
Temperature	0°C .. 45°C - Operation -20°C .. 70°C - Storage	
Humidity	85% rel. humidity - Operation 95% rel. humidity - Storage	non-condensing at 20°C non-condensing at 50°C
<b>Mechanical</b>		
Dimensions	102.7mm x 230mm x 20.6mm	
Weight	715g	
<b>Electrical</b>		
Power Supply	12V DC / 1A or USB only	dedicated power supply, no other loads connected; USB bus power limits, <a href="#">see end of document</a>

[back to top](#)

## 2 TAS28A\_BASE – USB Interface

TAS28A_BASE Specifications		
<b>Interface</b>	USB 2.0	
Datarate	480Mbit/sec	theoretical USB2.0 maximum
Internal Interface	I2S decoder for ADC data to 8-bit parallel bus to USB	FPGA, SW-reconfigurable
Data Buffers	2MB SRAM for AD & RPM data, 4kB FPGA SRAM for control data	for host latency compensation (>500ms for 8 AD/RPM channels at $f_s = 50\text{kHz}$ )
<b>Power Input</b>	10V – 18V DC, 700mA via LEMO connector, or USB powered	Attention: USB bus power limits <a href="#">see end of document</a>
IEPE Supply Voltage (ICP <sup>®</sup> , CCLD <sup>®</sup> )	24V $\pm 5\%$ / 20mA	21V for mobile systems, 10mA with USB power
Power Monitoring	10-bit ADC	all internal voltages are monitored by the MCU's 10-bit ADC
Temperature Sensor	$\pm 1.0^\circ\text{C}$ from $-25^\circ\text{C}$ to $+85^\circ\text{C}$ (max)	
<b>RPM Features</b>	4 RPM / TIS inputs on board	for specs see TIS48
<b>Clocks</b>	2 crystal oscillators on board: 25.6MHz 24.576MHz	for sampling frequencies of 50kHz / 100kHz / 200kHz or 48kHz / 96kHz / 192kHz
Clock Accuracy	$\pm 50\text{ppm}$	affects frequency measurements
Calibration	-	-
Power Consumption	1.2W	with 12V external supply, on-board TIS running at $f_s = 100\text{kHz}$
PCB Dimensions	212.5mm x 92.0mm	

[back to top](#)

### 3 TAD48 – Analog Input, Low Power

TAD48 Specifications		
Analog Inputs	2 BNC	
Input Coupling	AC / DC / IEPE Single-Ended (SE) / Differential (DIF)	IEPE: ICP <sup>®</sup> , CCLD <sup>®</sup> DIF: not for IEPE
Input Impedance, SE	33.7k $\Omega$ $\pm$ 2%    150pF max 26.8k $\Omega$ $\pm$ 2%    150pF max ( $\pm$ 30V)	
AC Coupling	$f_c = 4.7\text{Hz} \pm 10\%$ $f_c = 5.9\text{Hz} \pm 10\%$ ( $\pm 30\text{V}$ )	$f_c$ : -3dB corner frequency
IEPE Supply Current	2.2mA $\pm$ 5%	
IEPE Supply Voltage	depends on base card (24.5V or 21.0V for mob. sys.)	
IEPE Coupling	AC / SE DC / SE with $\pm 30\text{V}$ input range	
Input Range Max.	$\pm 30\text{V}$ peak	
Without Damage	60V <sub>pp</sub> DC/AC	
Gain Accuracy @ 1kHz	$\pm 0.5\text{dB}$ at 25°C $\pm 10^\circ\text{C}$	without calibration
Offset $\pm 10\text{V}$	$\leq 10\text{mV}$ (0.1% FS) / $\leq 12\text{mV}$ IEPE	
Offset $\pm 1\text{V}$	$\leq 2\text{mV}$ (0.2% FS) / $\leq 5\text{mV}$ IEPE	
Offset $\pm 100\text{mV}$	$\leq 1.5\text{mV}$ (1.5% FS) / $\leq 5\text{mV}$ IEPE	
Noise (BW 20kHz)	$\leq 15\mu\text{V}_{\text{rms}}$ RTI @ max gain	input shorted / 50 $\Omega$
SNR (BW 20kHz)	$\geq 106\text{dB}$ ( $\pm 10\text{V}$ ) $\geq 90\text{dB}$ ( $\pm 1\text{V}$ ) $\geq 105\text{dB}$ ( $\pm 30\text{V}$ )	shorted / 50 $\Omega$
THD (1kHz)	$\geq 90\text{dB}$ (-6dBFS) $\geq 80\text{dB}$ (-6dBFS, $\pm 1\text{V}$ )	
CMRR	$\geq 60\text{dB}$ @ 1kHz $\geq 50\text{dB}$ @ 50Hz	DC/DIF coupling
Crosstalk	$> 120\text{dB}$ @ 1kHz $> 110\text{dB}$ @ 10kHz	adjacent channels
Anti-Aliasing Filter	3-pole, $f_c = 160\text{kHz}$ -0.2dB @ 40kHz	$f_c$ : -3dB corner frequency
Passband	DC .. 0.40 * $f_s$	$f_s$ = sampling rate
PB Ripple (BW 20kHz)	$\pm 0.1\text{dB}$	
Stopband	0.50 * $f_s$	
Stopband Attenuation	$\geq 116\text{dB}$	
Phase Match	1 sample	adjacent channels
ADC Resolution	24 bits	

Sampling Rate	200kHz max	
Dynamic Range	$\geq 120\text{dB}$ (BW 20kHz)	input shorted / $50\Omega$ , incl. gain
SFDR	$\geq 110\text{dB}$ (BW 20kHz)	input shorted / $50\Omega$
ADC Group Delay	42 samples	compensated by TasAlyser
Calibration	ext. manual / SW calib.	recom. calibration interval: 1/year
Power Consumption	$\leq 0.4\text{W}$ without IEPE	at $f_s = 100\text{kHz}$ IEPE: + 60mW / channel
PCB Dimensions	70mm x 48mm	

[back to top](#)

#### 4 TAD48+ – Analog Input, High End

TAD48+ Specifications		
Analog Inputs	2 BNC	
Input Ranges	$\pm 30V / \pm 10V / \pm 5V / \pm 1V / \pm 0.5V$	
Input Coupling	AC / DC / IEPE Single-Ended (SE) / Differential (DIF)	IEPE: ICP <sup>®</sup> , CCLD <sup>®</sup> DIF: not for IEPE
Input Impedance, SE	130.4k $\Omega$ $\pm 1\%$    150pF max 310.3k $\Omega$ $\pm 1\%$    150pF max ( $\pm 30V$ )	
AC Coupling	$f_c = 4.8Hz \pm 5\%$ $f_c = 1.6Hz \pm 5\%$ ( $\pm 30V$ )	$f_c$ : -3dB corner frequency
IEPE Supply Current	2.3mA $\pm 5\%$	
IEPE Supply Voltage	depends on base card (24.5V or 21.0V for mob. sys.)	
IEPE Coupling	AC / SE DC / SE with $\pm 30V$ input range	limited bandwidth, see below
Input Without Damage	30V <sub>pp</sub> DC/AC 60V <sub>pp</sub> DC/AC, $\pm 30V$ input range	
Gain Accuracy @ 1kHz	$\pm 0.3dB$ at 25°C $\pm 10^\circ C$	without calibration
Offset	$\leq 0.05\%$ FS / $\leq 4mV$ with IEPE	AC or DC, SE, input open
Noise (BW 20kHz)	$\leq 2.1\mu V_{rms}$ RTI @ max gain	input shorted / 50 $\Omega$
SNR (BW 20kHz)	$\geq 112dB$ ( $\pm 10V$ ) $\geq 108dB$ ( $\pm 1V$ ) $\geq 104dB$ ( $\pm 0.5V$ ) $\geq 110dB$ ( $\pm 30V$ )	input shorted / 50 $\Omega$
THD (1kHz)	$\geq 90dB$ (-6dBFS) $\geq 70dB$ (-10dBFS, $\pm 30V$ )	
CMRR (1kHz)	$\geq 60dB$ $\geq 40dB$ ( $\pm 30V$ )	DC/DIF coupling
Crosstalk	$> 120dB$ @ 1kHz $> 110dB$ @ 10kHz $> 110dB$ @ 1kHz, $\pm 30V$ DIF $> 100dB$ @ 10kHz, $\pm 30V$ DIF	adjacent channels
Anti-Aliasing Filter	4-pole, $f_c = 100kHz$ -0.1dB @ 20kHz -0.4dB @ 40kHz	$f_c$ : -3dB corner frequency
Passband	$0.40 * f_s$	$f_s$ = sampling rate
PB Ripple (BW 20kHz)	$\pm 0.1dB$	all gains, except $\pm 30V$ , see below
Passband $\pm 30V$	-1dB @ 8kHz -3dB @ 40kHz	
Stopband	$0.50 * f_s$	

Stopband Attenuation	≥ 116dB	
Phase Match	1 sample	adjacent channels
ADC Resolution	24 bits	
Sampling Rate	200kHz max	
Overall Dynamic Range (BW 20kHz)	140dB	input shorted / 50Ω, incl. gain
SFDR	> 130dB	input shorted / 50Ω
ADC Group Delay	42 samples	compensated by TasAnalyser
Calibration	ext. manual/SW calib.	recom. calibration interval: 1/year
Power Consumption	≤ 0. 5W without IEPE	
PCB Dimensions	70mm x 48mm	

[back to top](#)



## 5 TIS48 – RPM / Encoder Input

TIS48 Specifications (also for TAS28 / TAS28A / TAS48 on-board TIS)				
Inputs	4 differential, RS-485			see connector layout below
Input Connector	D-Sub9, female			
Standard Input Voltage	3.3V, differential RS-485			
Input Options	<ul style="list-style-type: none"> <li>• Divider for 12V &amp; 24V signals</li> <li>• Single Ended Reference</li> <li>• Rising or Falling Edge Detection</li> </ul>			these options can be switched only for channel pairs
Maximum Input Voltage	24V <sub>PEAK</sub> single ended with attenuator			
Without Damage	±30V <sub>PEAK</sub>			
Pulse Detection Algorithm Frequency $f_{RPM}$ and Timing Resolution $T_{RPM}$	$f_s$	$f_{RPM}$	$T_{RPM}$	$f_s$ : TAS sampling rate
	200kHz	12.8MHz	78.125ns	
	100kHz	12.8MHz	78.125ns	
	50kHz	12.8MHz	78.125ns	
	25kHz	6.4MHz	156.25ns	
Frequency Dividers	up to 65534 (even numbers only)			
RPM Bandwidth	10MHz differential, 10MHz single-ended (min. 5V TTL)			with input frequency divider to keep divided signal < TAS' $f_s$
Frequency Accuracy	±50ppm			depends on base card's oscillator
Rotary IE / AB Detection Algorithm Frequency $f_{IEAB}$ and Timing Resolution $T_{IEAB}$	$f_s$	$f_{IEAB}$	$T_{IEAB}$	TIS48 only (FPGA firmware version ≥ 0x0B) IE = incremental encoder
	200kHz	25.6MHz	39.0625ns	
	100kHz	25.6MHz	39.0625ns	
	50kHz	25.6MHz	39.0625ns	
	25kHz	12.8MHz	78.125ns	
Rotary IE / AB Detection Max. IEAB Signal Input Frequency $f_{IEMAX}$	$f_s$	$f_{IEMAX}$		TIS48 only (FPGA firmware version ≥ 0x0B) quadrature decoding
	200kHz	3.2MHz		
	100kHz	2.1MHz		
	50kHz	1.5MHz		
	25kHz	0.7MHz		
RPM LED	2			to show any channel's activity
RPM LED Dividers	2 <sup>n</sup> ; with n = 0..14			
RPM LED Hold Time	25ms			
Isolation	≥ 1kV to TAS			cable shield must be connected on one side only
Calibration	-			
Power Consumption	≤ 0.5W			$f_s = 100kHz$
PCB Dimensions	70mm x 48mm			as module

[back to top](#)

### 5.1 TIS Connector

This is the layout of the **female 9-pin D-Sub** connector:

D-Sub 9 Pin	Signal	RPM Channel
1	RPM_A+	1+
2	RPM_C+	3+
3	RPM_D+	4+
4	RPM_B+	2+
5	GND	GND
6	RPM_A-	1-
7	RPM_C-	3-
8	RPM_D-	4-
9	RPM_B-	2-

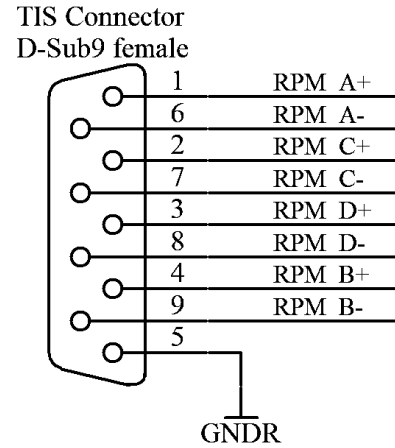

#### TIS: single-ended input signal switching thresholds

"-" input pin		SW setting		threshold (referred to single-ended signal on +input pin)		
adapter	voltage	high reference	attenuation	low to high ±20%	high to low ±20%	hysteresis ±20%
GND	0.0V	-	-	0.9V	-0.7V	1.6V
open	0.7V	-	-	2.5V	0.8V	1.7V
GND	0.0V	ON	-	3.9V	2.2V	1.7V
open	1.7V	ON	-	5.2V	3.5V	1.7V
GND	0.0V	-	ON	3.3V	1.1V	2.2V
open	0.8V	-	ON	6.8V	4.4V	2.4V
GND	0.0V	ON	ON	9.6V	7.5V	2.1V
open	1.7V	ON	ON	12.6V	10.2V	2.4V

#### TIS: differential input signal and connection requirements

- GND must be connected between differential source and TIS.
- **Cable shield** must be connected *on one side only* to prevent ground loops.

Common Mode Voltage $V_{CM}$	-2V .. +5V
$V_{CM}$ max. deviation between +/- input	±30%
Differential Input Threshold $V_{TH}$	1.4V
Hysteresis $V_{HY}$ ( $V_{CM} = 1.5V$ )	0.7V

[back to top](#)

## 6 TAS48\_SPOVL – Optical Digital Input

TAS48_SPOVL Specifications		
Input Connector	Versatile Link	optical receiver
Input Formats	S/PDIF, AES3	
Input Channels	2	stereo digital audio stream
<b>Sample Rate Conversion (SRC)</b>		
Sample Rate Input Range	11kHz .. 200kHz	automatic conversion to TAS sample rate
Sample Rate Input / Output Ratios Maximum	1:6 $F_{SI}:F_{SO}$ Up 6:1 $F_{SI}:F_{SO}$ Down	$F_{SI}$ : input sample rate $F_{SO}$ : output sample rate
Output Resolution	24 bits	
Interchannel Gain Mismatch	0dB	
Interchannel Phase Deviation	0°	
Gain Error	< -0.2dB	
Dynamic Range	> 130dB	depends on $F_{SI} / F_{SO}$ ratio
THD (1kHz)	> 110dB	depends on $F_{SI} / F_{SO}$ ratio
Passband (Up or Down Sampling)	$0.4535 * \min(F_{SI}, F_{SO})$	
Passband Ripple	$\pm 0.05\text{dB}$	
Stopband	$0.5465 * F_{SO}$ (output sample rate)	
Stopband Attenuation	125dB	
Group Delay	Total Group Delay = $8.7 / F_{SI} + 8 / F_{SO}$	
Calibration	-	
Power Consumption	$\leq 0.4\text{W}$	$f_s = 100\text{kHz}$
PCB Dimensions	70mm x 48mm	

[back to top](#)

## 7 Power Considerations for Mobile Systems

The TAS28A system is a very low power, high resolution, mobile data acquisition system. The mobile version can run on USB supply only, with some limitations.

These are the **limitations for USB supply only**:

- There must be no more than **3 slave modules** altogether
- Do not activate more than **5 IEPE channels** at a time.

**Attention:** This all depends very much on the laptop's USB supply. We have not yet found any one laptop that was not able to run with 4 slave modules, including 5 AD channels with activated IEPE. But this is slightly out of the USB specs, so if you'll encounter some trouble, please try an external supply to power TAS28A.

If you know your laptop has a whacky USB supply, use an external power supply from the start!

When TAS is **USB-powered** only, the following **restrictions** apply concerning TAD modules:

- a total maximum of **3 ADC modules** is allowed - only if these are supplied with **±2.7V** (TAD48 only)
- a total maximum of **2 ADC modules** is allowed on **TAS28A\_BASE**, if these are supplied with **±12V** (TAD48+)
- a total maximum of **5 channels with IEPE** supply are allowed

[back to top](#)